

These parts **MUST** be installed on surfaces supported by at least 1/2" thick plywood or 5/8" drywall material or stronger substrates.

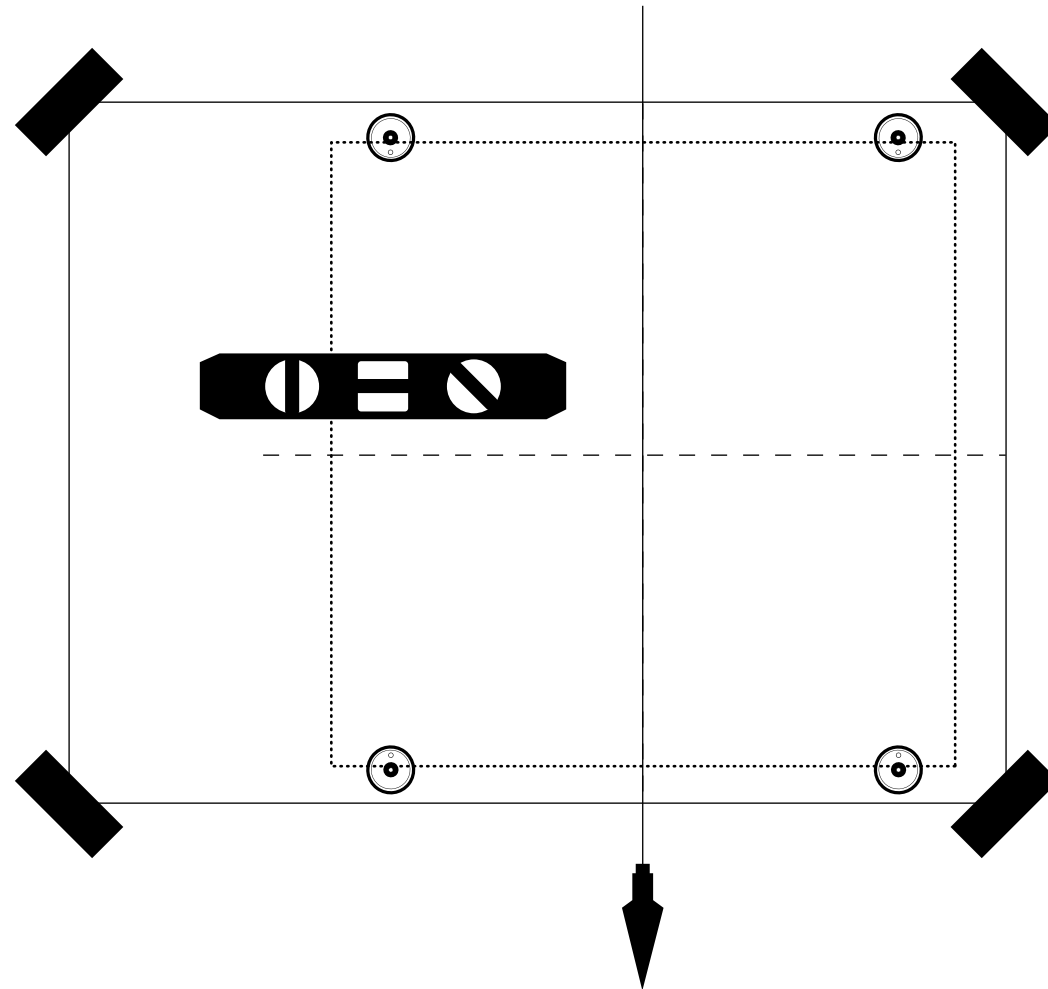

1. Tape this instruction sheet to the wall in the position in which you want to install the plaque. Use low tack painter's tape and level this sheet using the cross bars.

CROSS BAR

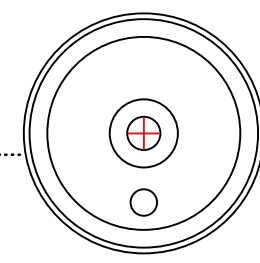
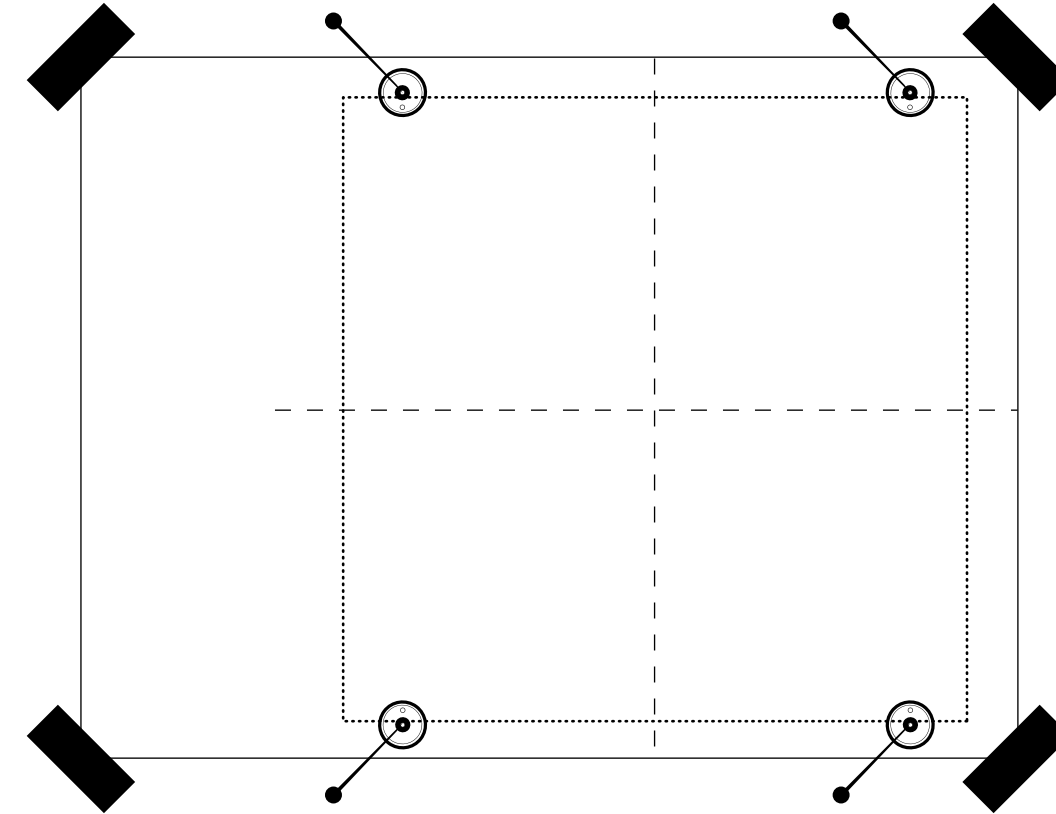
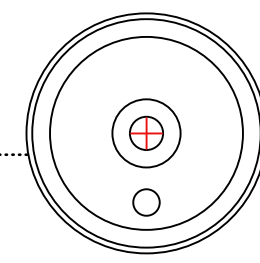

2. Mark screw holes with something sharp for screw positions.
3. Remove the instruction sheet.



CROSS BAR

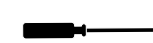

4. Install four (4) anchors if necessary.
5. Install the bottom two (2) brackets.

6. Install glass and top bracket.
7. Tighten the set screws.
8. Remove the protective cover from the adhesive on back of the cap before installing.

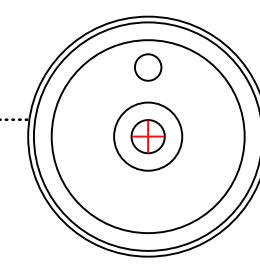
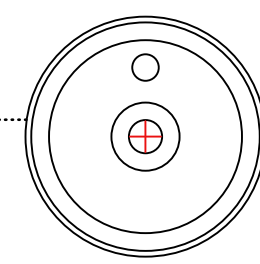
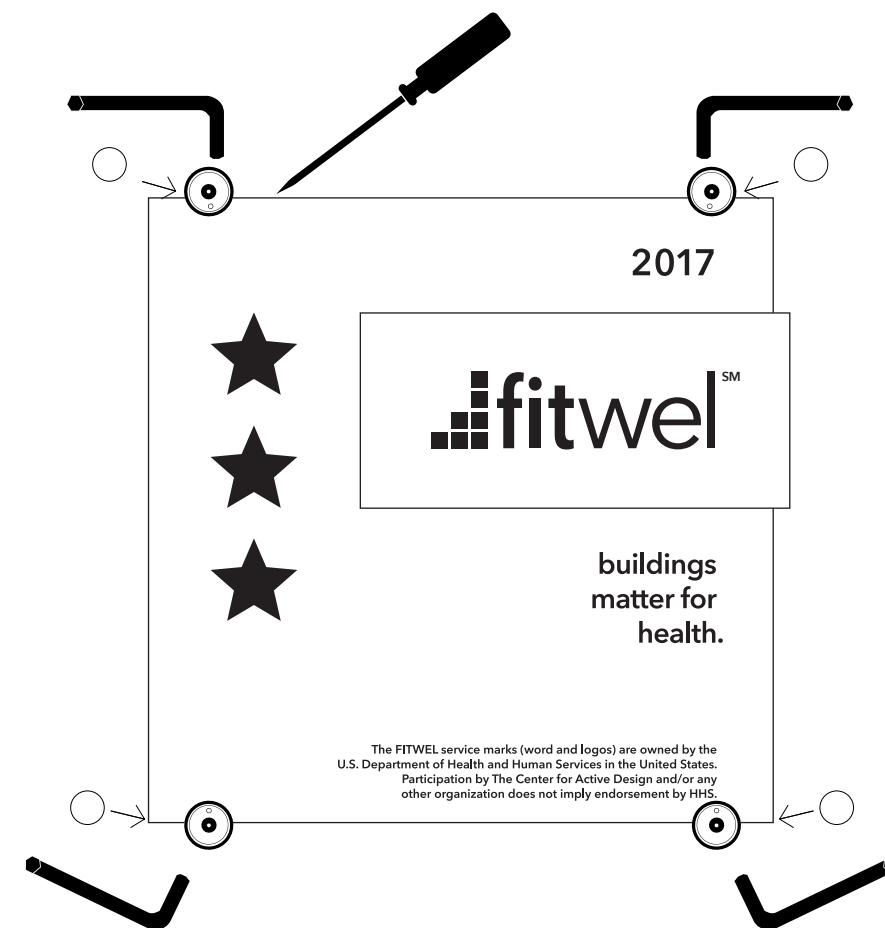
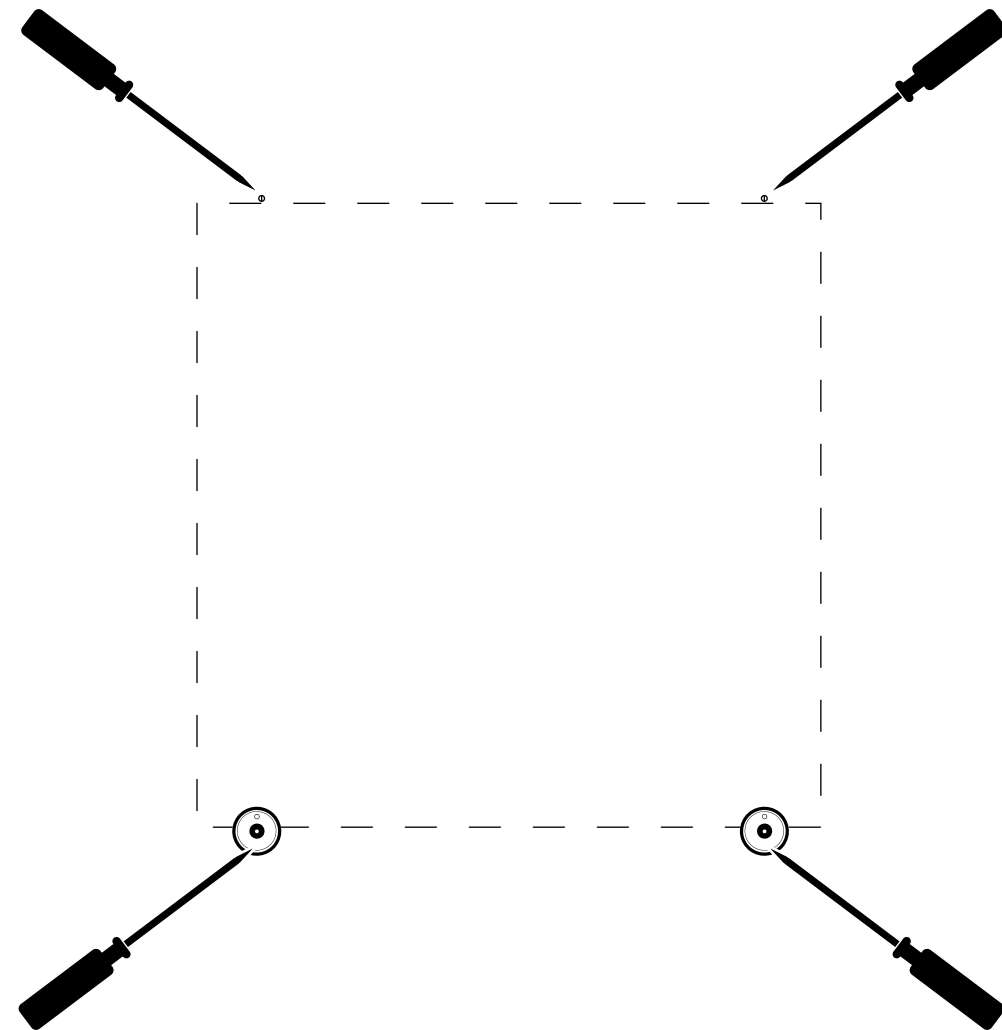

The FITWEL service marks (word and logos) are owned by the U.S. Department of Health and Human Services in the United States. Participation by The Center for Active Design and/or any other organization does not imply endorsement by HHS.